

## GIANT ATTACHMENTS

Here is a part of our wide range of attachments. The complete range of attachments can be found in the folder "attachments" or on our website [www.giant-attachments.com](http://www.giant-attachments.com).



[WWW.GIANT-ATTACHMENTS.COM](http://WWW.GIANT-ATTACHMENTS.COM)

Pictures may differ from actual product.

## WHEEL LOADERS

GIANT wheel loaders are totally designed and produced in own management in Oisterwijk (the Netherlands). In 2009 TOBROCO-GIANT has started with the development for new models for the existing range. These new models will replace the existing ones. For development TOBROCO-GIANT is using a sophisticated 3-dimensional design program. Thus before taken a machine in production, it's performance can be tested already. During the development of the new models TOBROCO takes care of the demands and needs of their customers. TOBROCO is a specialist in compact wheelloaders. In the modern plant in Holland they build the GIANT wheel loaders. We work with the best suppliers: Kubota, Rexroth. GIANT is robust, durable and quality made in Holland!

Also TOBROCO-GIANT offers you a very big variety of implements. The majority of these implements is designed and produced by TOBROCO-GIANT, and because of this, the implements are optimally adapted for your GIANT, which is more efficient this way.



### TOBROCO-GIANT

Industrielaan 2,  
5061 KC Oisterwijk (Netherlands)  
Tel.: +31 (0)13-5211212  
Fax: +31 (0)13-5234045  
Internet: [www.tobroco-giant.com](http://www.tobroco-giant.com)  
E-Mail: [info@tobroco.com](mailto:info@tobroco.com)

All technical data in this brochure refer to series models that have been tested under operating conditions typical of Central Europe and describe their standard functions. Specifications and their modes of functionality as well as accessories listed in this brochure depend on the individual model and on the options available with a particular product as well as the statutory requirements of the country of sale. Illustrations used in this brochure may show products that have not been mentioned or that are not available as series production machines. The descriptions, illustrations, weights and technical data published herein are non-binding in nature and represent the technical status at the time the document went to press. Because of ongoing development, we reserve the right to make changes, without prior notice, to the design, specification, visual appearance and technology of our products. Should you require special functions that would be available only by using additional components and/or under special circumstances, please feel free to contact us. We will be happy to answer any questions you may have and to provide further information regarding whether and under what conditions applying to the product and the target environment such special functions might be feasible. If you have any concerns about the load capacity or operation of our products in certain working conditions or environments, we recommend that you perform a test run under controlled conditions. Despite meticulous attention to detail, we cannot exclude the possibility that our products may not conform to illustrations or stated dimensions, or that errors may have occurred in calculation or during printing, or that the information given here may be incomplete. Consequently, we do not accept liability for the accuracy or completeness of the information supplied in this brochure. All matters relating to our product warranty are contained within our General Terms and Conditions. We expressly decline to provide additional guarantees. Any liability over and above that contained within our General Terms and Conditions is excluded.

P001300111 C-SERIE EN V117

# GIANT

Team TOBROCO

Industrielaan 2, 5061 KC Oisterwijk  
Tel.: +31 (0)13-5211212  
Fax: +31 (0)13-5234045  
Internet: [www.tobroco-giant.com](http://www.tobroco-giant.com)  
E-Mail: [info@tobroco.com](mailto:info@tobroco.com)



D267  
D337T

## WHEEL LOADERS

A flexible and compact jack of all trades



D267 - D337T

# WHEEL LOADERS

To full fill the needs and demands of her customers TOBROCO offers a wide range of wheel loaders. This range consists out of 25 different types of loaders with a service weight between 1000 kg and 4150 kg. In this leaflet, we will show you the range of GIANT's with a service weight of 2000 kg to 2100 kg. For further information about other types and implements we refer to our other leaflets or our website ([www.tobroco-giant.com](http://www.tobroco-giant.com)).

# TECHNICAL SPECIFICATIONS



## D267 - D337T

These mini wheel loaders are equipped with Kubota diesel engines. With 26 and 33 HP. The machines are equipped with a Bosch Rexroth automotive hydraulic pump which contributes to very smooth and powerful driving characteristics. Heavy axles, four-wheel drive, mechanical driveshaft, and an automatic differential lock mode ensure that the machine can use its power for maximum results. Strong pivoting articulation, all wheels at all time in contact with the ground and the machine moves with maximum traction.

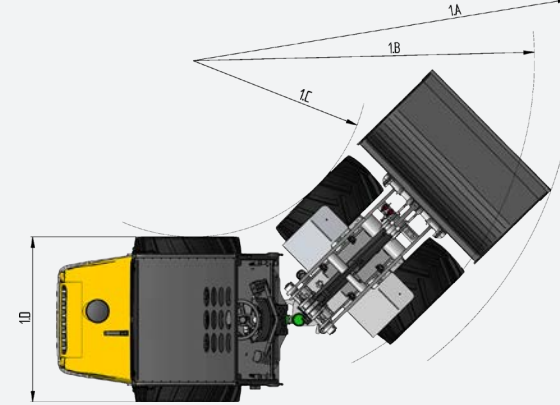
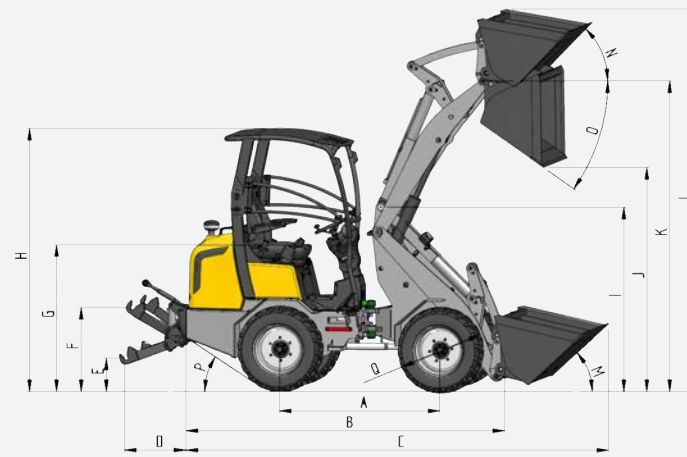

The GIANT wheel loaders are equipped with the latest Kubota diesel engines. Which meet the latest emission requirements. The engines are cleaner and have less CO2 emissions. Standard machines are fitted with large water and oil coolers. The engines are mounted on specially designed silent blocks so that vibration and noise level are reduced to a minimum. In order to increase the comfort GIANT wheel loaders have silent blocks under the driver's platform. With a luxury suspension seat with arm and headrest. This machine gives the luxury that every driver want. With the standard hydraulic quick-change system is the connecting and disconnecting of the attachments very easy.



10.0x75-15.3 AS (76x26 cm)  
104 cm machine width

31x15.5-15 AS (76x37 cm)  
128 cm machine width



31x15.5-15 TR-06 (76x37 cm)  
128 cm machine width

31x15.5-15 Skid (79x40 cm)  
131 cm machine width

	D267	D337T
Engine	3 cylinder Kubota 26 hp / 19 kW	3 cylinder Kubota Turbo 33 hp / 24 kW
Transmission	Hydraulic 4WD with automotive control, drive shafts	Hydraulic 4WD with automotive control, drive shafts
Driving speed	0 - 12 km/h	0 - 18 km/h
Working hydraulics	45 L/min (180 bar)	45 L/min (180 bar)
Tipping load <sup>1</sup>	1.400 kg	1.450 kg
Lift capacity	1.600 kg	1.650 kg
Weight <sup>2</sup>	2.000 kg	2.100 kg
Parking brake	Drum brake / mechanical	Drum brake / mechanical
Diesel / Oil capacity	37 L / 56 L	37 L / 56 L
Attachment bracket	GIANT STANDARD Hydraulic	GIANT STANDARD Hydraulic
Tyres Vehicle width	10.0/75-15.3 AS 1.040 mm	10.0/75-15.3 AS 1.040 mm

	D267	D337T
A Wheel base	1.524	1.524
B Total length without bucket	2.986	2.986
C Total length with bucket	3.700	3.700
D Length 3-point lifting arm (option)	622	622
E Min height 3 point hitch	134	134
F Max. height 3 point hitch	797	797
G Seat height	1.256	1.256
H Max. height with ROPS/FOPS safetyroof	2.300	2.300
Max. height with cabin	2.284	2.284
Max. Foldable roof (up)	2.348	2.348
Max. Foldable roof (down)	1.970	1.970
I Height frontframe	1.480	1.480
J Max. dump bucket	1.988	1.988

	D267	D337T
S	1.430 kg	1.450 kg
T	1.220 kg	1.250 kg
U	910 kg	950 kg
U (extended lifting arm)	840 kg	880 kg
V	705 kg	745 kg
W	1.975 kg	2.000 kg
X	1.250 kg	1.270 kg
Y	970 kg	1.000 kg

Sizes in mm. Tippingload in straight position, without extra counterweights. Data is subject to change.

<sup>1</sup> Measured on hinge point in straight position.

<sup>2</sup> Measured with standard bucket and driver.

	D267	D337T
K Max. bucket pin height	2.825	2.825
max. bucket pin height extended lift arm	2.920	2.920
L Height with bucket	3.392	3.392
M Roll back angle ground level	43°	43°
N Roll back angle	53°	53°
O Max. dump angle	47°	47°
P Max. drive angle	30°	30°
Q Diameter standaard tyre	Ø 760	Ø 760
1A Maximum radius	2.635	2.635
1B Outer turning radius	2.257	2.257
1C Inner turning radius	1.021	1.021
1D Total width (vanaf)	1.040	1.040

Hydraulic quick change GIANT, 3e hydr. Function, width range of attachments designed and produced by TOBROCO.

ROPS/FOPS safety roof, comfortable suspension seat with armrests and headrest. Driving platform on Rubber suspension silent blocks.



Cyclone filter standard, big kombi-cooler (oil and water)  
2 big hydraulic oil tanks, modern Kubota engine.