

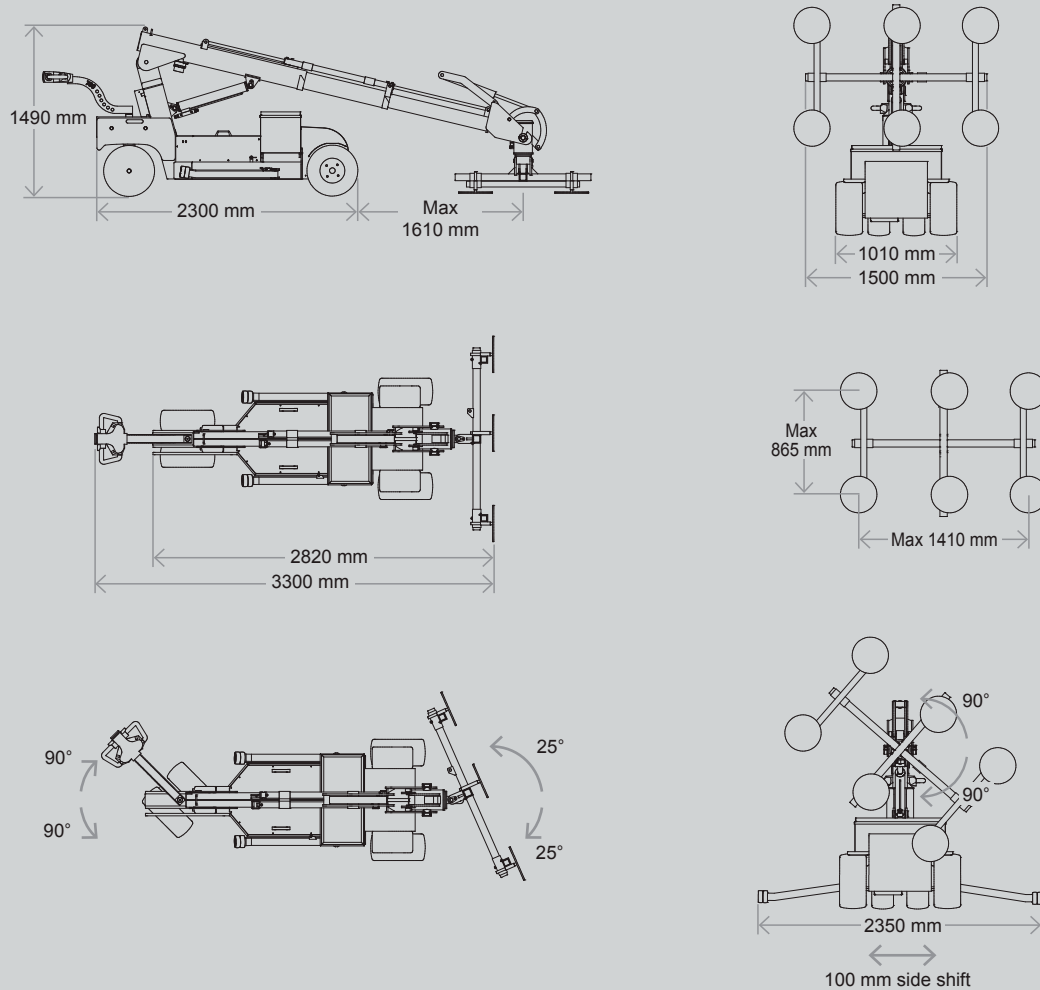

Smart lift
SL 408 OUTDOOR

Product information and specifications

BASIC DATA (PROVISIONAL)



TECHNICAL SPECIFICATIONS

Lifting cap. arm in/out	1,000 / 280 kg - 2,200 / 620 lbs.
Lifting height	4,400 mm / 173 in.
Extension of arm	2 x 830 mm / 2 x 33 in.
Tip from horizontal	42° back / 86 ° fwd
Side shift	100 mm / 4 in
Charging voltage	230V / 110V
Charging time	Approx. 8 hrs.
Battery	4 x 134 Ah AGM
Running period	Up to 8 hrs.
Front wheel drive	2000 W AC
Suction pads	6 x Ø400mm / Ø16 in.
Curb weight	1,300 kg / 2,866 lbs.
Class	IP 65

LIFTING DIAGRAM

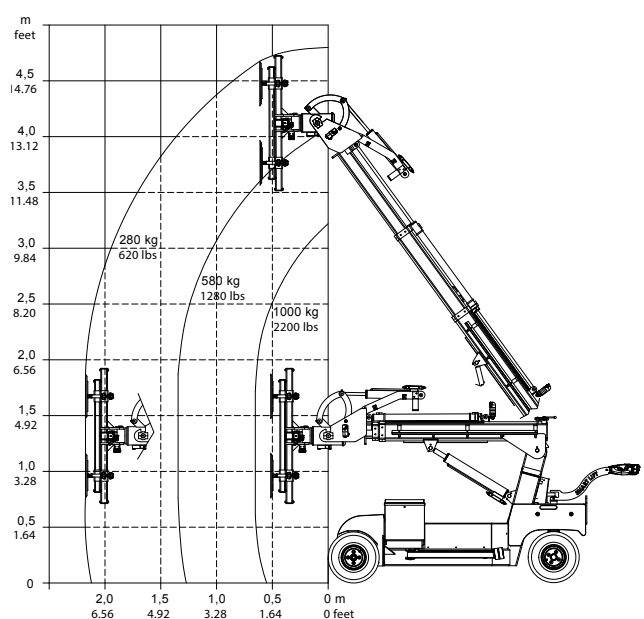

www.instant.no

INSTANT

Norway

Tel.: +47 23 19 11 00
info@instant.no

Lithuania

Tel.: +370 5 233 1096
info@instant.lt

Latvia

Tel.: +371 263 58 152
info@instantlatvija.lv

Estonia

Tel.: +372 680 76 33
info@instant.ee